

GAZELLE[®]

GM4535 Electric Cut-Off Machine User Manual



General power tool safety warnings



WARNING Read all safety warnings,

instructions, illustrations and

specifications provided with this power tool.

Failure to follow all instructions listed below may result in electric shock, fire and/or serious injury.

Save all warnings and instructions for future reference.

The term "power tool" in the warnings refers to your mains-operated (corded) power tool or battery-operated (cordless) power tool.

1) Work area safety

- a) **Keep work area clean and well lit.** *Cluttered or dark areas invite accidents.*
- b) **Do not operate power tools in explosive atmospheres, such as in the presence of flammable liquids, gases or dust.** *Power tools create sparks which may ignite the dust or fumes.*
- c) **Keep children and bystanders away while operating a power tool.** *Distractions can cause you to lose control.*

2) Electrical safety

- a) **Power tool plugs must match the outlet. Never modify the plug in any way. Do not use any adapter plugs with earthed (grounded) power tools.** *Unmodified plugs and matching outlets will reduce risk of electric shock.*
- b) **Avoid body contact with earthed or grounded surfaces, such as pipes, radiators, ranges and refrigerators.** *There is an increased risk of electric shock if your body is earthed or grounded.*
- c) **Do not expose power tools to rain or wet conditions.** *Water entering a power tool will increase the risk of electric shock.*
- d) **Do not abuse the cord. Never use the cord for carrying, pulling or unplugging the power tool. Keep cord away from heat, oil, sharp edges or moving parts.** *Damaged or entangled cords increase the risk of electric shock.*
- e) **When operating a power tool outdoors, use an extension cord suitable for outdoor use.** *Use of a cord suitable for outdoor use reduces the risk of electric shock.*
- f) **If operating a power tool in a damp location is unavoidable, use a residual current device (RCD) protected supply.** *Use of an RCD reduces the risk of electric shock.*

3) Personal safety

- a) **Stay alert, watch what you are doing and use common sense when operating a power tool. Do not use a power tool while you are tired or under the influence of drugs, alcohol or medication.** *A moment of inattention while*

operating power tools may result in serious personal injury.

- b) **Use personal protective equipment. Always wear eye protection.** *Protective equipment such as a dust mask, non-skid safety shoes, hard hat or hearing protection used for appropriate conditions will reduce personal injuries.*
 - c) **Prevent unintentional starting. Ensure the switch is in the off-position before connecting to power source and/or battery pack, picking up or carrying the tool.** *Carrying power tools with your finger on the switch or energising power tools that have the switch on invites accidents.*
 - d) **Remove any adjusting key or wrench before turning the power tool on.** *A wrench or a key left attached to a rotating part of the power tool may result in personal injury.*
 - e) **Do not overreach. Keep proper footing and balance at all times.** *This enables better control of the power tool in unexpected situations.*
 - f) **Dress properly. Do not wear loose clothing or jewellery. Keep your hair and clothing away from moving parts.** *Loose clothes, jewellery or long hair can be caught in moving parts.*
 - g) **If devices are provided for the connection of dust extraction and collection facilities, ensure these are connected and properly used.** *Use of dust collection can reduce dust-related hazards.*
 - h) **Do not let familiarity gained from frequent use of tools allow you to become complacent and ignore tool safety principles.** *A careless action can cause severe injury within a fraction of a second.*
- ### 4) Power tool use and care
- a) **Do not force the power tool. Use the correct power tool for your application.** *The correct power tool will do the job better and safer at the rate for which it was designed.*
 - b) **Do not use the power tool if the switch does not turn it on and off.** *Any power tool that cannot be controlled with the switch is dangerous and must be repaired.*
 - c) **Disconnect the plug from the power source and/or remove the battery pack, if detachable, from the power tool before making any adjustments, changing accessories, or storing power tools.** *Such preventive safety measures reduce the risk of starting the power tool accidentally.*
 - d) **Store idle power tools out of the reach of children and do not allow persons unfamiliar with the power tool or these instructions to operate the power tool.** *Power tools are dangerous in the hands of untrained users.*
 - e) **Maintain power tools and accessories. Check for misalignment or binding of moving parts, breakage of parts and any other condition**

that may affect the power tool's operation. If damaged, have the power tool repaired before use. Many accidents are caused by poorly maintained power tools.

- f) **Keep cutting tools sharp and clean.** Properly maintained cutting tools with sharp cutting edges are less likely to bind and are easier to control.
- g) **Use the power tool, accessories and tool bits etc. in accordance with these instructions, taking into account the working conditions and the work to be performed.** Use of the power tool for operations different from those intended could result in a hazardous situation.
- h) **Keep handles and grasping surfaces dry, clean and free from oil and grease.** Slippery handles and grasping surfaces do not allow for safe handling and control of the tool in unexpected situations.

5) Service

- a) **Have your power tool serviced by a qualified repair person using only identical replacement parts.** This will ensure that the safety of the power tool is maintained.

Safety instructions for cut - off machines

1) Cut - off machine safety warnings

- a) **Position yourself and bystanders away from the plane of the rotating wheel .** The guard helps to protect the operator from broken wheel fragments and accidental contact with wheel
- b) **Use only bonded reinforced or diamond cut - off wheels for your power tool .** Just because an accessory can be attached to your power tool , it does not assure safe operation .
NOTE 1 The wording "bonded reinforced" or "diamond "is used as applicable depending on the designation of the tool .
- c) **The rated speed of the accessory must be at least equal to the maximum speed marked on the power tool .** Accessories running faster than their rated speed can break and fly apart .
- d) **Wheels must be used only for recommended applications .** For example : do not grind with the side of a cut - off wheel . Abrasive cut - off wheels are intended for peripheral grinding , side forces applied to these wheels may cause them to shatter .
- e) **Always use undamaged wheel flanges that are of correct diameter for your selected wheel .** Proper wheel flanges support the wheel thus reducing the possibility of wheel breakage .
- f) **The outside diameter and the thickness of your accessory must be within the capacity rating of your power tool .** Incorrectly sized accessories cannot be adequately guarded or controlled .
- g) **The arbour size of wheels and flanges must properly fit the spindle of the power tool .**

Wheels and flanges with arbour holes that do not match the mounting hardware of the power tool will run out of balance , vibrate excessively and may cause loss of control .

- h) **Do not use damaged wheels .** Before each use , inspect the wheels for chips and cracks . If the power tool or wheel is dropped, inspect for damage or install an undamaged wheel . After inspecting and installing the wheel , position yourself and bystanders away from the plane of the rotating wheel and run the power tool at maximum no load speed for one minute . Damaged wheels will normally break apart during this test time .
 - i) **Wear personal protective equipment .** Depending on application , use face shield, safety goggles or safety glasses . As appropriate , wear dust mask , hearing protectors , gloves and shop apron capable of stopping small abrasive or workpiece fragments . The eye protection must be capable of stopping flying debris generated by various operations . The dust mask or respirator must be capable of filtering particles generated by your operation . Prolonged exposure to high intensity noise may cause hearing loss .
 - j) **Keep bystanders a safe distance away from work area .** Anyone entering the work area must wear personal protective equipment . Fragments of workpiece or of a broken wheel may fly away and cause injury beyond immediate area of operation .
 - k) **Position the cord clear of the spinning accessory .** if you lose control , the cord may be cut or snagged and your hand or arm may be pulled into the spinning wheel .
 - l) **Regularly clean the power tool ' s air vents .** The motor ' s fan can draw the dust inside the housing and excessive accumulation of powdered metal may cause electrical hazards .
 - m) **Do not operate the power tool near flammable materials .** Do not operate the power tool while placed on a combustible surface such as wood . Sparks could ignite these materials .
 - n) **Do not use accessories that require liquid coolants .** Using water or other liquid coolants may result in electrocution or shock .
NOTE 2 The above warning does not apply for power tools specifically designed for use with a liquid system .
- #### 2) Kickback and related warnings
- Kickback is a sudden reaction to a pinched or snagged rotating wheel . Pinching or snagging causes rapid stalling of the rotating wheel which in turn causes the uncontrolled **cutting unit** to be forced upwards toward the operator .
For example , if an abrasive wheel is snagged or

pinched by the workpiece, the edge of the wheel that is entering into the pinch point can dig into the surface of the material causing the wheel to climb over or kick out. Abrasive wheels may also break under these conditions.

Kickback is the result of power tool misuse and / or incorrect operating procedures or conditions and can be avoided by taking proper precautions as given below.

a) Maintain a firm grip on the power tool and position your body and arm to allow you to resist kickback forces. *The operator can control upward kickback forces, if proper precautions are taken.*

b) Do not position your body in line with the rotating wheel. *If kickback occurs, it will propel the cutting unit upwards toward the operator.*

c) Do not attach a saw chain, woodcarving blade, segmented diamond wheel with a peripheral gap greater than 10 mm or toothed saw blade. *Such blades create frequent kickback and loss of control.*

d) Do not "jam" the wheel or apply excessive pressure. Do not attempt to make an excessive depth of cut. *Overstressing the wheel increases the loading and susceptibility to twisting or binding of the wheel in the cut and the possibility of kickback or wheel breakage.*

e) When the wheel is binding or when interrupting a cut for any reason, switch off the power tool and hold the cutting unit motionless until the wheel comes to a complete stop. Never attempt to remove the wheel from the cut while the wheel is in motion otherwise kickback may occur. *Investigate and take corrective action to eliminate the cause of wheel binding.*

f) Do not restart the cutting operation in the workpiece. Let the wheel reach full speed and carefully re-enter the cut. *The wheel may bind, walk up or kickback if the power tool is restarted in the workpiece.*

g) Support any oversized workpiece to minimize the risk of wheel pinching and kickback. *Large workpieces tend to sag under their own weight. Supports must be placed under the workpiece near the line of cut and near the edge of the workpiece on both sides of the wheel.*

UK power plug warnings:

Your product is fitted with an BS 1363-1 approved electric plug with internal fuse approved to BS 1362. If the plug is not suitable for your socket, it should be removed and an appropriate plug should be fitted in its place by an authorized customer service agent. The replacement plug should have the same fusing as the original plug. The severed plug must be disposed of to avoid a possible shock hazard and should never be inserted into a mains socket elsewhere.

Symbol



WARNING



To reduce the risk of injury, user must read instruction manual



Always wear eye protection

Technical Data

Model		GM4535	
Rated Power Input	W	2000	
No-load Speed	/min	3800	
Max. Cutting Angle	°	45	
Max. Opening Size	mm	191	
Wheel Size	mm	355x3x25.4	
Max. Cutting Capacity	Round Bar	mm	65
	Pipe	mm	120
	Profiled Bar	mm	120x130
Net Weight	kg	16	

※ Due to the continuing program of research and development, the specifications herein are subject to change without prior notice.

Function Description

*Cautions

1. Power Voltage

Before connecting the machine to a power source (receptacle, outlet, etc.), be sure the voltage supplied is the same as that specified on the nameplate of the machine.

2. Protective Earthing Conductor

The machine must be grounded to prevent the operator from electric shock, and it is equipped with a standard three-wire and grounding-type receptacle to adapt to the normal grounding receptacle. The green and yellow cable is known as the earth wire. Do not connect it to the live wire.

3. Switch

To avoid accident, always be sure that the tool is switched OFF before plugging in.

4. Extension Cable

If the extension cable is far away from the power supply, an outdoor-specific extension cable with sufficient capacity should be used. A cable with small capacity will lead to a decrease in voltage, resulting in damage to the cable.

Always be sure that the extension cable is in good condition before use.

Be sure to keep the cable away from the working area and in a proper location, so as not to cut the cable or be entangled by the wheel during work, resulting in cable damage or accidents.

*Cutting Operation

1. Hold the handle firmly. Switch on the machine and wait until the wheel attains full speed before lowering gently into the cut.
2. When the wheel contacts the workpiece, gradually bear down on the handle to perform the cut.
3. When the cut is completed, switch off the machine and wait until the wheel has come to a complete stop before returning the handle to the fully elevated position.
4. It's dangerous for you to remove or install the cutting material when the wheel is rotating.

*Installing or Removing the Wheel

Mount the inner flange onto the spindle and fit the wheel on over the inner flange, then fit the outer flange and the washer onto the spindle in turn. Push in the stopper pin and secure the hex. bolt with a socket wrench. Follow the installing procedures in reverse to removing the wheel.

Caution: Always be sure that the machine is switched OFF and unplugged before installing or

removing the wheel. Please tighten the hex bolt securely to avoid severe injury. Be sure to pull out the stopper pin after installing the wheel or before switching on the machine.

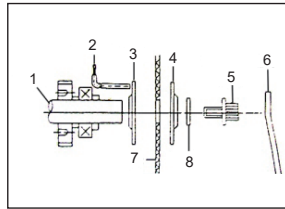

1. Drive Spindle
2. Stopper Pin
3. Inner Flange
4. Outer Flange
5. Hex. Bolt
6. Socket Wrench
7. Wheel
8. Washer

*Adjusting the Vise

The maximum angle of the vise is 45°.

To change the cutting angle, first loosen the two bolts of the vise (A), and then slide vise (A) forward or backward to desired location, and securely tighten bolts.

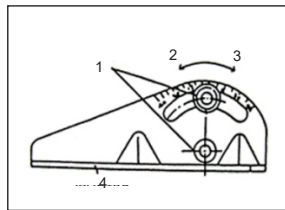

1. Bolts
2. Direction A
3. Direction B
4. Vise A

*Spacer Block

When the cut-off wheel has worn down and became smaller, you can use a spacer block which is slightly narrower than the workpiece as shown in figure to utilize the wheel economically.

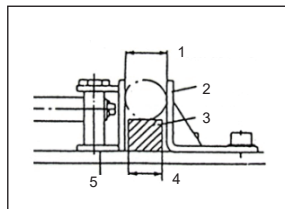

1. Diameter of Workpiece
2. Stationary Vise A
3. Spacer Block
4. Width of Spacer Block
5. Adjustable Vise B

*Movement of the stationary vise (A)

When the product leaves the factory, the maximum opening size of the vise is 156mm.

When you need to increase the size, you can loosen the two fixing bolts and move the vise (A) along the opening position on the base. At this time, the opening size of the vise can be adjusted to 191mm.

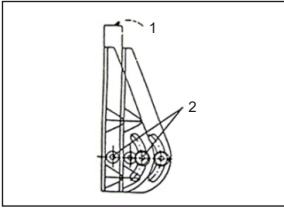

1. The opening size of the vise can be adjusted to 191mm
2. Bolts

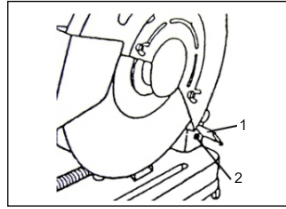

1. Spark Guard
2. Screw

***Movement of the adjustable vise (B)**

To lock work, push screw rod toward work until the vise (B) is in contact with the workpiece, lower quick release lever and turn crank to tighten.

To release work, turn crank to loosen vise (B), lift quick release lever up, and pull screw shaft away from work.

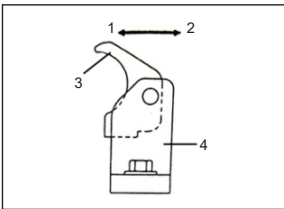

1. Forward Direction of Screw Rod
2. Backward Direction of Screw Rod
3. Quick Release Lever
4. Screw Rod Base

***Cutting Long Workpieces**

Long workpiece must be supported by blocks of non-flammable material on either end so that it will be level with the base top.

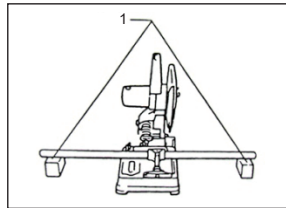

1. Blocks

***Lock Chain**

Fix the machine for easily moving and storing. Lower the handle to the position where you can attach the lock chain to the hook on the handle.

Lower the handle and release the lock chain from the hook before putting the machine into use.

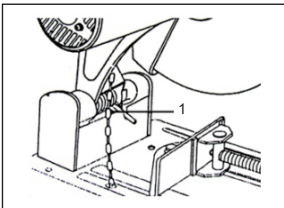

1. Lock Chain

***Cutting at an Angle**

When cutting workpiece over 65mm wide at an angle, attach a straight piece of wood (spacer) over 190mm long and 45mm wide to the guide plate as shown in the figure. Attach this spacer with screws through the holes in the guide plate.

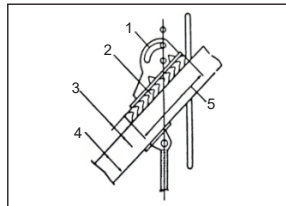

1. Guide Plate
2. Straight Piece Of Wood (Spacer)
3. Over 45mm Wide
4. Over 45mm Wide
5. Over 190mm Long

***Spark Guard**

A spark guard is equipped for this machine to avoid many sparks flying around in operation. Loosen the screw on the bracket and adjust the spark guard to position at which minimum sparks will fly around.

***Switch Action**

To start the tool, simply pull the switch button. Release the button to stop. For continuous operation, pull the button and then push in the lock button. To stop the tool from the locked position, pull the button fully and then release it.

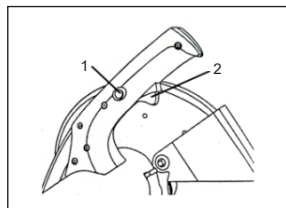

1. Lock Button
2. Switch Button

*Wood Block

When the cut-off wheel has worn down considerably, use a spacer block of sturdy, non-flammable material behind the workpiece as shown in the figure. You can more efficiently utilize the worn wheel by using the midpoint on the periphery of the wheel to cut the workpiece.

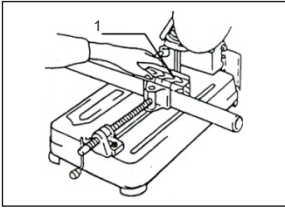

1.Wood Block

MAINTENANCE AND INSPECTION

CAUTION:

Always be sure that the machine is switched off and unplugged before attempting to perform inspection or maintenance.

·Changing Cut-off Wheel

When the cut-off wheel has worn down considerably and results in reduced efficiency, replace with a new one immediately.

·Inspecting the Mounting Screws

Regularly inspect all mounting screws and ensure that they are properly tightened. Should any of the screws be loose, retighten them immediately. Failure to do so could result serious hazard.

·After Use

Disconnect the machine after operation and store it out of reach of children. Brush off accumulation of dust on the base.

·Lubrication

To prolong the service life of this machine, lubricate the machine's active parts every month (refer to the name of each part).

- 1.Spinner Part Between Bracket and Clevis Pin with Head
- 2.Screw Rod
- 3.Moving Part of Vise (B)

·Replacing Carbon Brushes

Use a screwdriver to remove the brush holder caps, take out the worn carbon brushes, insert the new ones and secure the brush holder caps.

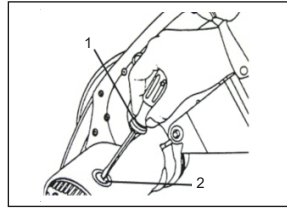

1.Screwdriver
2.Brush Holder Cap

Remove and check the carbon brushes regularly. Replace when they wear down to the limit mark. Keep the carbon brushes clean and free to slip in the holders. Both carbon brushes should be replaced at the same time.

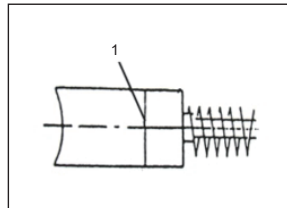

1.Limit Mark

If the replacement of the supply cord is necessary, this has to be done by the manufacturer or his agent in order to avoid a safety hazard.

Environmental Protection

Waste Disposal

The damaged tools, accessories and waste package materials should be sorted for eco-friendly recycling and in accordance with local laws.

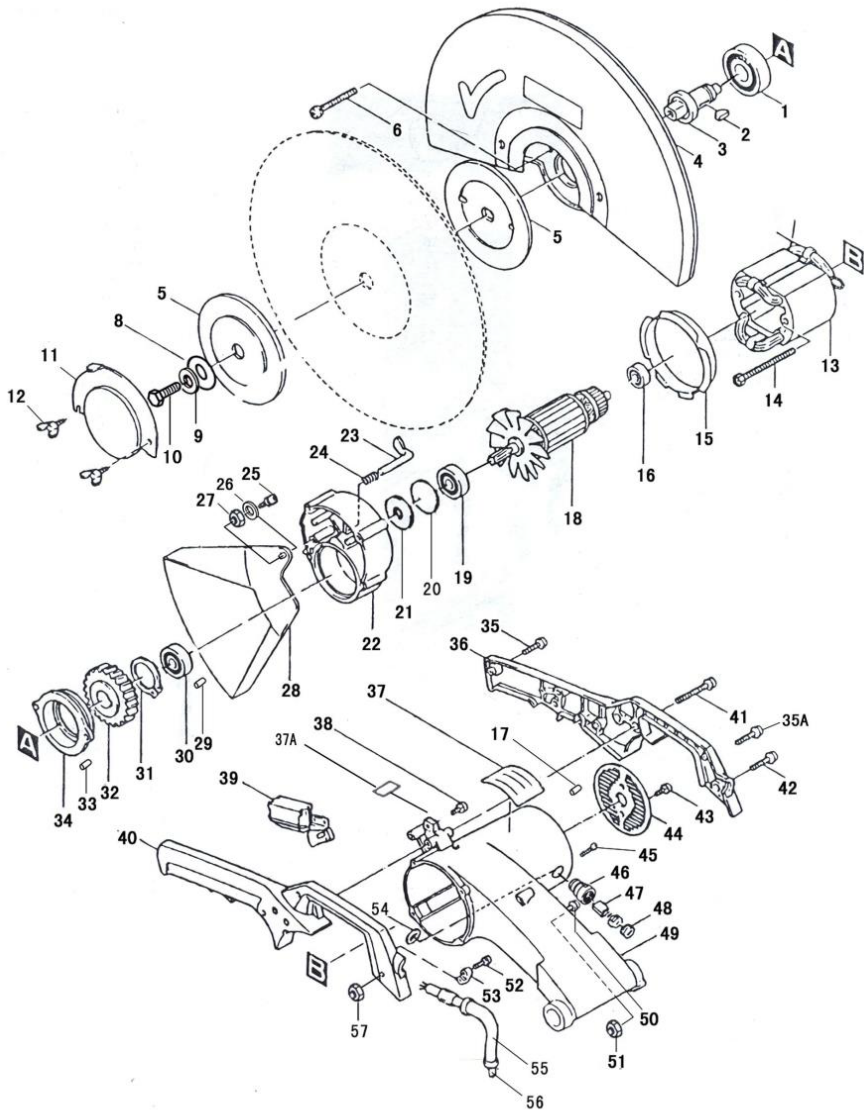

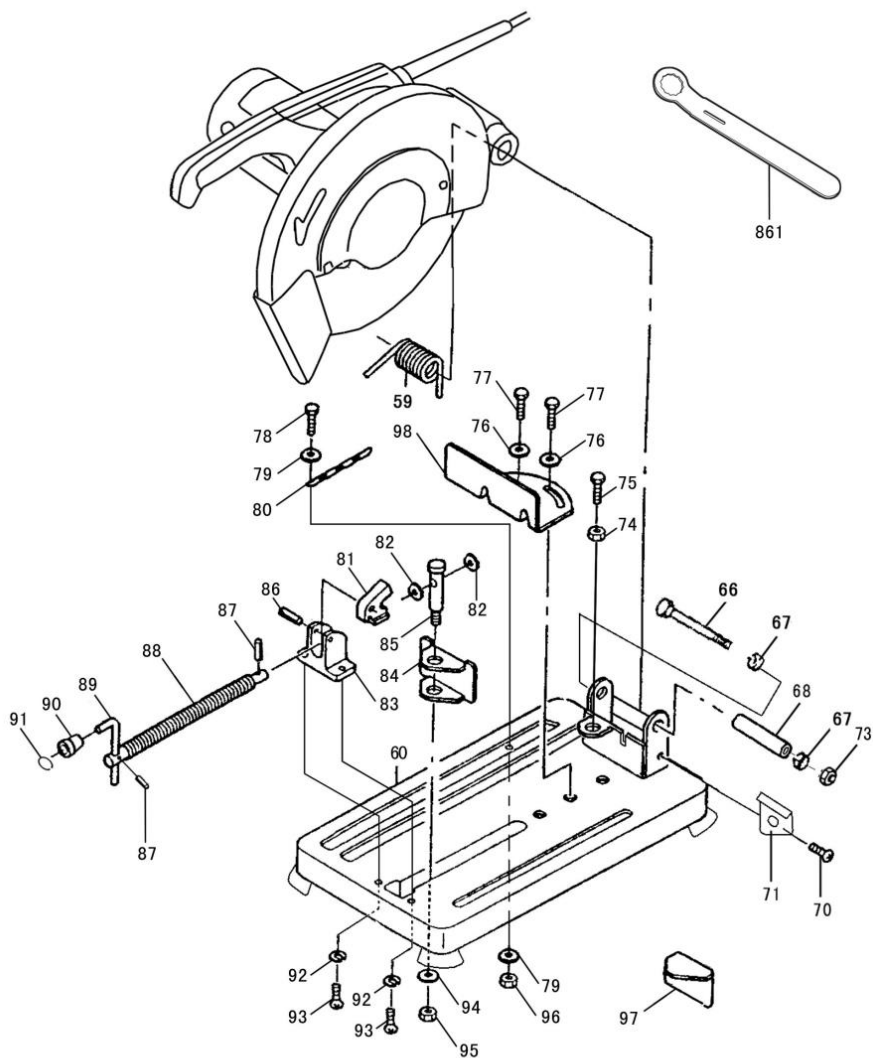

EXPLANATION OF GENERAL VIEW

1	Ball Bearing 6204VV	25	Hex Socket Head Screw M6×12
2	Woodruff Key 5×7.5×16	26	Adjustable Guard
3	Drive Spindle	27	Hex Lock Nut M6
4	Safety Guard	28	Adjustable Guard
5	Flange	29	Rubber Pin
6	Pan Head Screw M5×52 (with Spring and Flat Washer)	30	Ball Bearing 6000ZZ
8	Washer	31	Circlip for Shaft
9	Spring Washer	32	Gear
10	Hex. Bolt M10×20	33	Rubber Pin
13	Stator Assembly	34	End Cap
14	Pan Head Screw M5×80 (with Spring and Flat Washer)	35	Pan Head Tapping Screw ST4×22
15	Baffle Plate	35A	Pan Head Tapping Screw ST4×18
16	Ball Bearing 6200ZZ	36	Left –half Handle Set
17	Rubber Pin	37	Nameplate
18	Armature Assembly	37A	Label
19	Ball Bearing 6202ZZ	38	Pan Head Screw M5×10 (with Spring and Flat Washer)
20	O Ring	39	Switch
21	Wave Washer	40	Right-half Handle Set
22	Gear Housing Cover	41	Pan Head Screw M5×52 (with Spring and Flat Washer)
23	Lever	42	Pan Head Screw M5×30 (with Spring and Flat Washer)
24	Compression Spring	43	Pan Head Screw M5×10 (with Spring and Flat Washer)

EXPLANATION OF GENERAL VIEW

44	Rear Cover	72	Hex. Lock Nut M6
45	Hex. Socket Head Screw with Flat Point M5×8	73	Lock Nut M16
46	Carbon Brush Holder	861	Wrench
47	Carbon Brush		
48	Brush Holder Cap		
49	Motor Housing		
50	Adjusting Bolt M6×20		
51	Hex. Lock Nut M6		
52	Pan Head Tapping Screw ST4×16		
53	Strain Relief		
54	Insulation Washer		
55	Cord Guard		
56	Cord		
57	Nut M5		
59	Torsion Spring		
60	Base Assembly		
66	Hex. Bolt M16×170		
67	Washer		
68	Shaft		
70	Pan Head Screw M8×10		
71	Spark Guard		

INNOVATION
PERFORMANCE
SAFETY
CONFIDENCE
GAZELLE

GAZELLE

sales@gazelleindustrial.com | www.gazelleindustrial.com