

Plastic pipe welding

Socket welding

ROWELD P 63 S-6 Sword

Socket welding unit Ø 20 - 63 mm



Product profile

APPLICATION AREA

Socket welding unit for use with heating spigots and heating sockets Ø 20 - 63 mm with three simultaneously usable combinations for welding sockets, pipes and fittings up to Ø 63 mm

KEY FEATURES

- Increased flexibility and combination options for every day use
- Long service life and according to DVS regulations
- All important information at a glance
- Safe operation with the temperature control as per DVS regulations

KEY FEATURES

- Light and handy for fatigue-free use
- Simple to use even in confined spaces
- Floor stand is available at all times

TECHNICAL DATA

Power:	800 W
Model:	Thermostatic or electronically controlled
Pipe diameter:	For sockets, pipes and fittings from Ø 20 - 63 mm
Voltage:	230 V, 50/60 Hz 110/115 V, 50/60 Hz

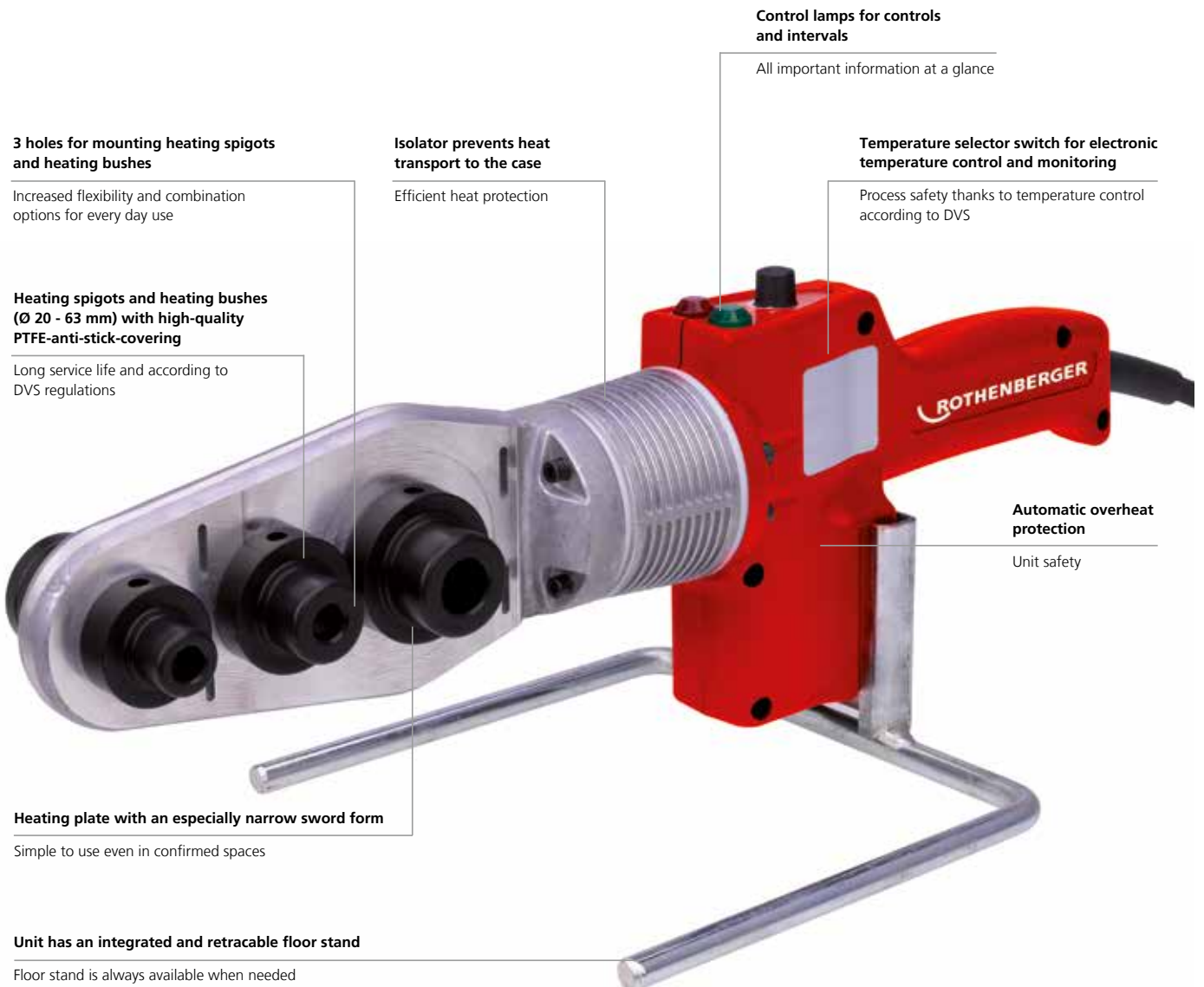

Plastic pipe welding

Socket welding

ROWELD P 63 S-6 Sword sets

P 63 S-6 Sets include: Heating spigots, hex key size 6 (No. 321216), socket-head screws, table mounting clamp, loor stand, plastic carrying case

Electronically controlled for a constant temperature!



Fig. P 63 S-6, thermostatically controlled



Fig. P 63 S-6, electronically controlled

Model	Working range Ø mm	Power watts	Description	 kg	230 V	110/115 V
P 63 S-6 set	20, 25, 32, 40, 50, 63	800	thermostatic	5.30	053893X	1000001245
P 63 S-6 set	20, 25, 32, 40, 50, 63	800	electronically	5.30	053891X	

P 63 S-6 set thermostatically controlled





Secure workbench operation, integrated holder for the table mounting clamp



Heating spigots and sockets (Form A) for P 63 S-6

With high-quality non-stick Teflon coating with a long service life and manufactured according to DVS regulations

Working range Ø mm	 g	No.
20	80	53511
25	100	53512
32	170	53513

Working range Ø mm	 g	No.
40	260	53514
50	370	53515
63	600	53516