

G9303

Operating Manual



Phase Sequence and Motor Rotation Indicator

I. Preface

Dear users:
 Congratulations on your purchase of G9303 Phase Sequence and Motor Rotation Indicator. To operate the instrument correctly, please read this Manual carefully and especially its "Safety Information" before use.
 After reading it, you are recommended to keep the manual properly. Please keep it with the instrument together or place it in an accessible location for future use.

II. Overview

G9303 Phase Sequence and Motor Rotation Indicator (hereinafter referred to be as G9303) is a handheld battery powered instrument, widely used to identify phase orientation of three-phase industrial equipments and motor rotation direction.

III. Unpacking Inspection

Check the product for any crack or scratch. If any item is missing or damaged, please contact nearby service center.

- Standard items included in the shipment:
- The Instrument-----1 pc
 - Operating Manual-----1pc
 - Test Leads-----3pcs
 - Alligator Clips-----3pcs
 - Carrying Bag-----1pc
 - 9V Battery-----1pc

IV. Safety Information

- ⚠ Caution:** Specifies the conditions and actions that may cause damage to G9303.
- ⚠ Warning:** Specifies the conditions and actions that may pose hazards to the User.

To prevent electric shocking or fire, it is necessary to comply with the following codes:

- It is required to read through following safety instructions prior to operation or maintenance;
- Comply with local and national safety codes;
- It is required to use personal protective equipments;
- It is required to operate the instrument as per the instructions of manufacturer, or otherwise the safety features/protective measures provided by the instrument may be affected;
- Inspect the insulator of testing lead for damage or exposed metal; inspect testing lead for continuity and replace the damaged testing lead.
- Please take extreme caution when working with voltage higher than 30Vacrms, 42Vac Peak or 60Vdc, for it may pose electric hazard.
- Keep finger away from alligator clip contact and behind the finger protection device when using alligator clip.
- Adverse impact will be caused to the measurement by the impedance generated by the transient current of extra operating circuit in parallel;
- Please ensure the instrument operates normally prior to measuring dangerous voltage (30V ac rms, 42 V AC peak value or 60 V DC above)
- Testing time should not exceed 10min when measuring the voltage 500V ~ 600V AC above;
- Do not operate G9303 when removing any part;
- Do not operate G9303 around explosive gas, steam or dust;
- Do not operate G9303 in a wet place;
- It is required to remove testing lead from the power and G9303 prior to replacing the battery.

V. Functional Description

5.1 Symbols

Following symbols are applied on G9303 or in the manual.

	Risk of electric shock
	Warning
	Dangerous voltage
	Double or reinforced insulation
	Grounding
	AC or DC
	Comply with European Union directives
CAT III	Conforms to Overvoltage Category III, Pollution Degree 2 as per IEC61010-1. CATIII refers to the degree of protection against the transients and usually includes the equipments in fixed installations (eg: electricity meter and primary overcurrent protection device).

5.2 Instrument Description

See the instrument indicator, button and jack as shown in Figure 1:

Graphical description

- ① Phase input jack (U, V, W);
- ② L1, L2, L3 phase indicators;
- ③ Clockwise rotation LED indicator;
- ④ Counter-clockwise rotation LED indicator;
- ⑤ Power switch
- ⑥ Motor location indicator
- ⑦ Power LED indicator
- ⑧ Instruction Table

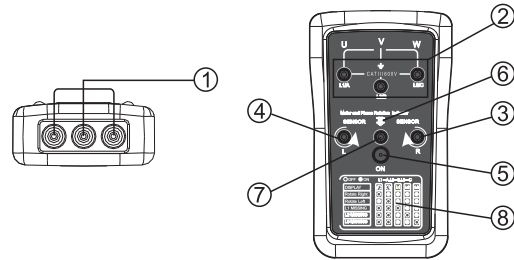

Figure 1

5.3 Operating Instruction

5.3.1 Determine Phase Sequence (Contact Type)

- Insert test leads (L1,L2,L3) into the corresponding input terminals of G9303(U,V,W) respectively and then connect them to alligator clips.
- Then connect alligator clips in L1, L2 and L3 order to three phases of the system (eg: U,V and W terminals of three-phase instrument).
- Press down "ON" button, G9303 power indicator illuminates, release it, the button springs up automatically and the indicator turns off. Therefore you need to press down "ON" button in order to begin the test. When ON is pressed down, "Clockwise" (R) or "Counter-clockwise" (L) rotation indicator illuminates, indicating three-phase system is under "Positive" or "Negative" phase sequence.

5.3.2 Check Rotary Field (Motor Rotation, Non-Contact Type)

- Remove all test leads away from G9303;
- Place G9303 towards the motor, in parallel with motor shaft. The bottom of the instrument should face the shaft (namely, G9303 is located in a direction contrary to that of the motor). Refer to Figure 1 for motor location indicator.
- Press "ON" button, power indicator illuminates and the test begins. "Clockwise" (R) or "Counter-clockwise" (L) rotation indicator illuminates, indicating the motor is rotating in a "clockwise" or "counter-clockwise" direction. See Figure 2 for details.

R LED indicator is on when the motor rotates clockwise.

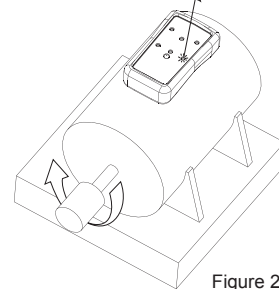

Figure 2

5.4 Detect Magnetic Field

Place G9303 into solenoid valve, press "ON" button. If "Clockwise" (R) or "Counter-clockwise" (L) rotation indicator illuminates, indicating magnetic field exists in the area.

VI. Maintenance

⚠ Note

To prevent damage to G9303:

- Repairing or Maintaining G9303 can only be performed by qualified technicians.
- Make sure you know clearly precise calibration procedures and function tests, and read enough maintenance information.

- Do not use corrosive or solution since those substances will cause damage to the chassis of G9303.
- Prior to cleaning, remove all testing leads from G9303.

Replacement and disposal of battery

⚠ ⚠ Note, Warning

- To prevent electric shocking, it is necessary to remove all testing leads from G9303 prior to replacing the battery.
- G9303 contains 9V/6F22 battery, do not discard the battery with other solid wastes and the used battery should be handed over to the qualified waste collector or dangerous substance transporter for proper treatment and disposal.

Please replace the battery as follows and see the Figure 3:

- Remove all testing leads from G9303.
- Take off the protective casing.
- Place G9303 with face down on the non-abrasive surface, and screw out screws on the battery cover with proper screw driver.
- Take off battery cover from G9303 and take out battery after loosening the battery buckle.
- Replace battery as per the method shown in the figure, and watch out for the battery polarity.
- Reinstall the battery cover with screws.
- Load the protective casing for G9303.

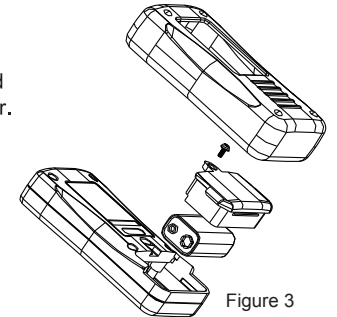

Figure 3

VII. Specification

Ambient	
Working temperature	0°C ~ 40°C (32°F ~ 104°F)
Storage temperature	0°C ~ 50°C (32°F ~ 122°F)
Altitude	2000 m
Humidity	≤95%
Pollution Degree	2
IP grade	IP 40
Mechanical	
Dimensions	123mm×71mm×29mm (4.8in×2.8in×1.1in)
Weight	192g
Safety	
Compliances	Comply with IEC61010/EN61010, IEC 61557-7
Maximum operating voltage (Ume)	600V
CAT Rating	CAT III 600V
Electrical	
Power	9V/6F22 battery
Battery life	approximately 1 year of normal use
Phase indication	
Nominal voltage	90VAC ~ 600VAC
Frequency range (fn)	15Hz ~ 400 HZ
Nominal test current (subject to each phase)	<3 mA
Non-contact rotating magnetic field indication	
Nominal voltage rotating direction value	30VAC ~ 600VAC
Frequency range (fn)	15Hz ~ 400 HZ
Nominal test current (subject to each phase)	<3 mA

END

The manual information is subject to changes without prior notice!